



**GARAGE  
TECHNIC**



**AUTOMOTIVE GARAGE EQUIPMENT**

**PRODUCT  
CATALOG**

[www.garagetechnic.com](http://www.garagetechnic.com)



## ALV01 Counterbalanced Garage Cranes

### Technical Details

Model	ALV 01
Capacity (Ton)	1
B (Mm)	1150
C (Mm)	950
D (Mm)	3200
J (Mm)	1170
Weight (Kg)	500

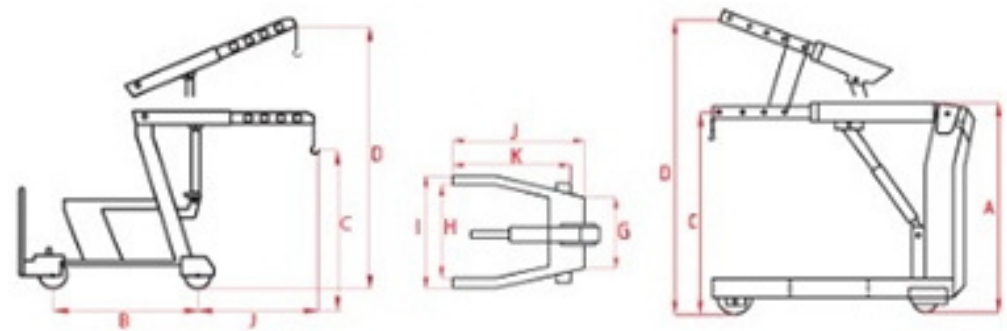



## ALV06 Straight Heavy Type Hydraulic Garage Cranes

### Technical Details



Model	ALV 06
Capacity Ton	3
Dimension A (Mm)	2425
Dimension B (Mm)	2000
Dimension C (Mm)	1420
Dimension D (Mm)	3870
Dimension E (Mm)	270
Dimension G (Mm)	1170
Dimension H (Mm)	1050
Dimension I (Mm)	1170
Dimension J (Mm)	-
Dimension K (Mm)	2000
Weight Kg	250

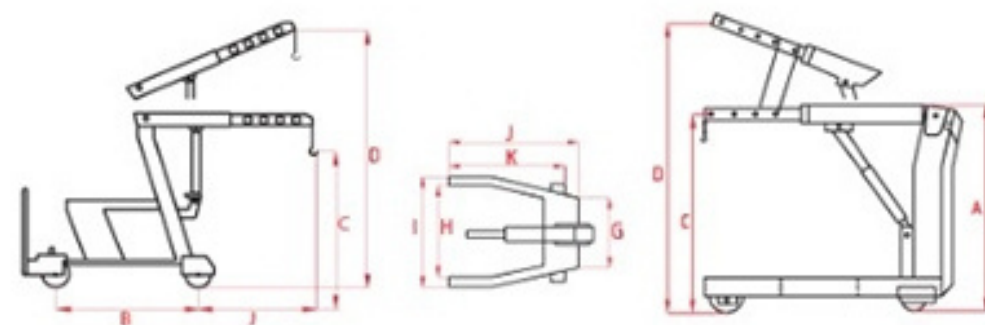



## LV Flat Hydraulic Garage Cranes

### Technical Details



Model	Capacity Ton	Dimension A (Mm)	Dimension B (Mm)	Dimension C (Mm)	Dimension D (Mm)	Dimension G (Mm)	Dimension H (Mm)	Dimension I (Mm)	Dimension K (Mm)	Weight (Kg)
LV 01	1	1960	1670	1117	2850	410	1000	1115	1337	146
LV 02	2	1900	1670	1117	2850	410	1000	1115	1337	170
LV 03	3	1900	1800	1300	1900	460	1200	1320	1480	185

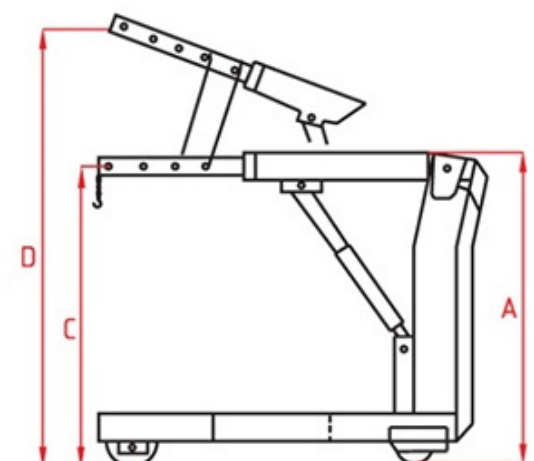
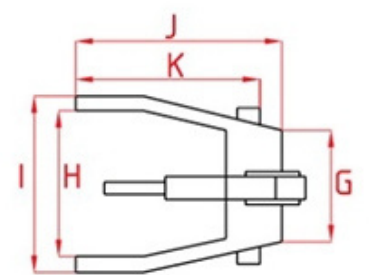



## LKV01 Folding Hydraulic Garage Cranes

### Technical Details

Model	LKV 01
Capacity (Ton)	1
A (Mm)	1800
B (Mm)	1650
D (Mm)	2800
E (Mm)	160
F (Mm)	650
H (Mm)	1040
I (Mm)	1250
Weight (Kg)	105





## HGK02A Low Profile 2 Ton Hydraulic Garage Jack

### Technical Details



Model	HGK 02A
Capacity (Ton)	2
A (Mm)	70
B (Mm)	500
C (Mm)	1000
D (Mm)	145
E (Mm)	370
F (Mm)	850
Weight (Kg)	45

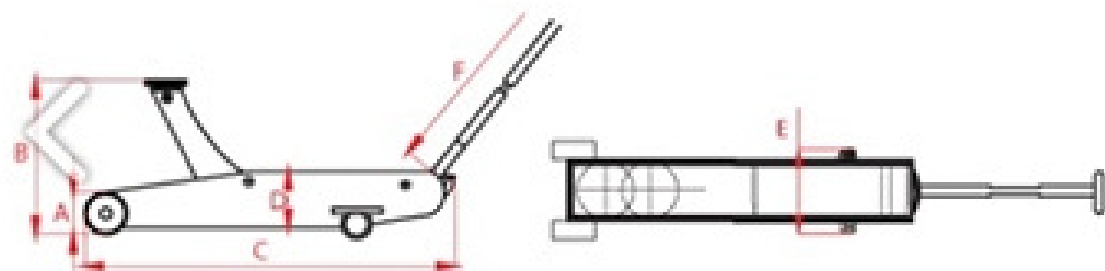



## HGK02 Normal Profile 2 Ton Hydraulic Garage Jack

### Technical Details



Model	HGK 02
Capacity (Ton)	2
A (Mm)	120
B (Mm)	500
C (Mm)	1100
D (Mm)	160
E (Mm)	360
F (Mm)	850
Weight (Kg)	47

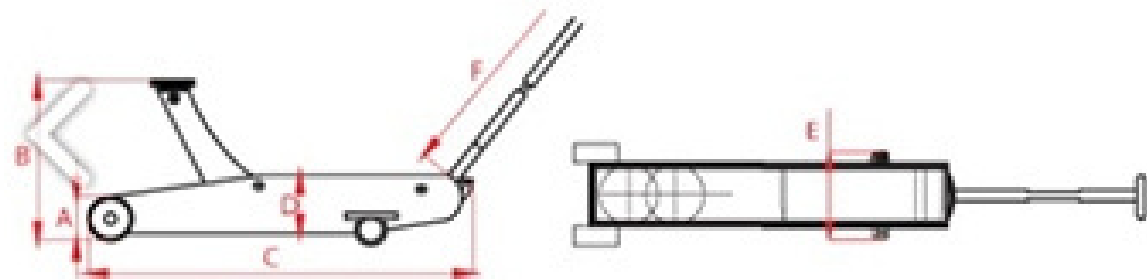



**HGK03**  
Normal Profile 3 Ton Hydraulic Garage Jack

**Technical Details**



Model	HGK 03
Capacity (Ton)	3
A (Mm)	130
B (Mm)	500
C (Mm)	1335
D (Mm)	170
E (Mm)	360
F (Mm)	850
Weight (Kg)	55

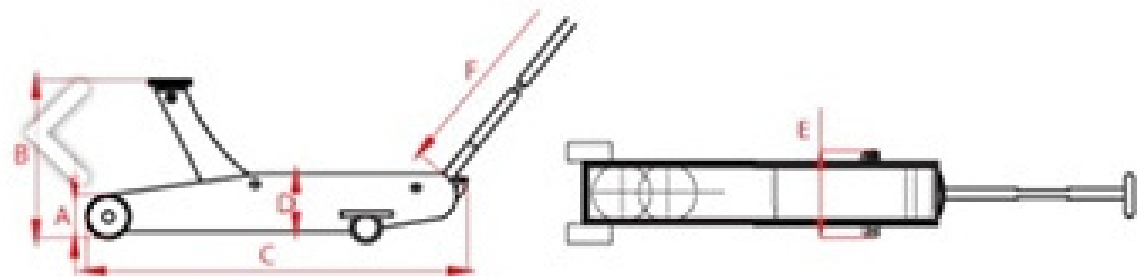





## HGK03A Low Profile 3 Ton Hydraulic Garage Jack

### Technical Details



Model	HGK 03A
Capacity (Ton)	3
A (Mm)	80
B (Mm)	515
C (Mm)	1300
D (Mm)	145
E (Mm)	386
F (Mm)	850
Weight (Kg)	65

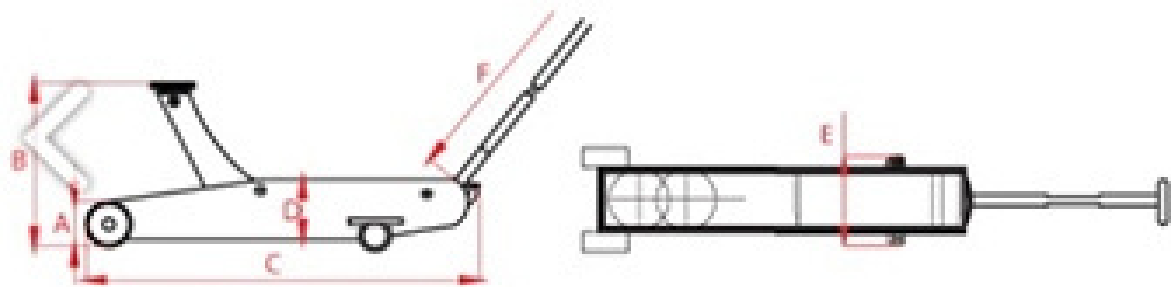



## HGK05 5 Ton Hydraulic Garage Jack

### Technical Details



Model	HGK 05
Capacity (Ton)	5
A (Mm)	140
B (Mm)	570
C (Mm)	1500
D (Mm)	210
E (Mm)	380
F (Mm)	850
Weight (Kg)	74

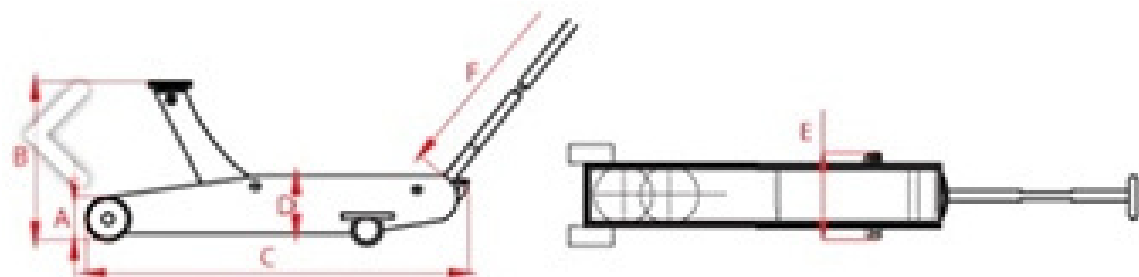



## HGK10 Normal 10 Ton Hydraulic Garage Jack

### Technical Details



Model	HGK 10
Capacity (Ton)	10
A (Mm)	200
B (Mm)	650
C (Mm)	1667
D (Mm)	270
E (Mm)	450
F (Mm)	980
Weight (Kg)	140

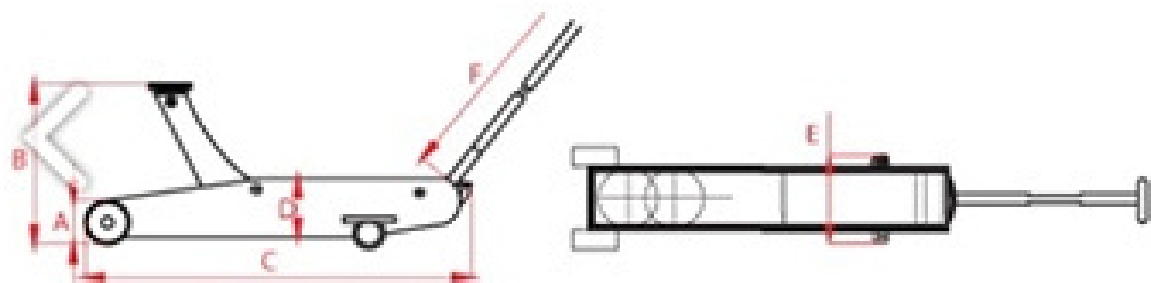



## HGK15K Short / Normal 15 Ton Hydraulic Garage Jack

### Technical Details



Model	HGK 15K
Capacity (Ton)	15
A (Mm)	200
B (Mm)	650
C (Mm)	1667
D (Mm)	270
E (Mm)	450
F (Mm)	980
Weight (Kg)	140

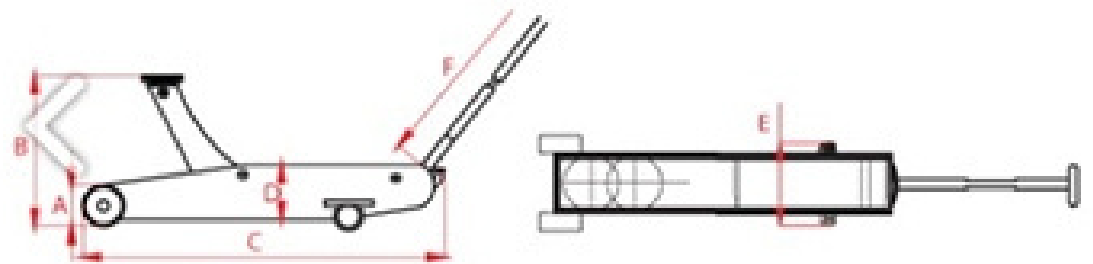



## HGK15U Long / Normal 15 Ton Hydraulic Garage Jack

### Technical Details



Model	HGK 15U
Capacity (Ton)	15
A (Mm)	200
B (Mm)	650
C (Mm)	1900
D (Mm)	270
E (Mm)	450
F (Mm)	980
Weight (Kg)	150

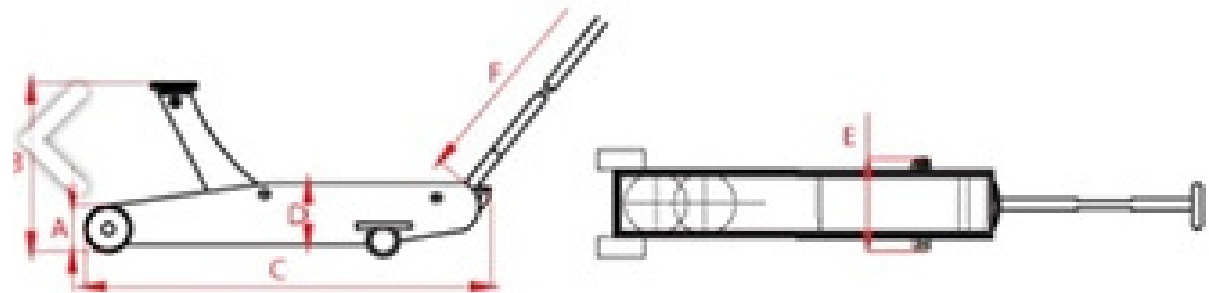



## HGK20 Normal 20 Ton Hydraulic Garage Jack

### Technical Details



Model	HGK 20
Capacity (Ton)	20
A (Mm)	200
B (Mm)	650
C (Mm)	2150
D (Mm)	270
E (Mm)	450
F (Mm)	980
Weight (Kg)	175

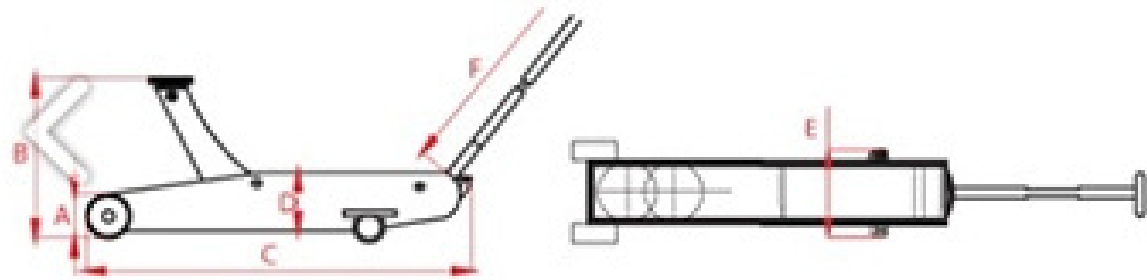



## HGK30 Normal 30 Ton Hydraulic Garage Jack

### Technical Details



Model	HGK 30
Capacity (Ton)	30
A (Mm)	200
B (Mm)	650
C (Mm)	2350
D (Mm)	270
E (Mm)	450
F (Mm)	980
Weight (Kg)	200

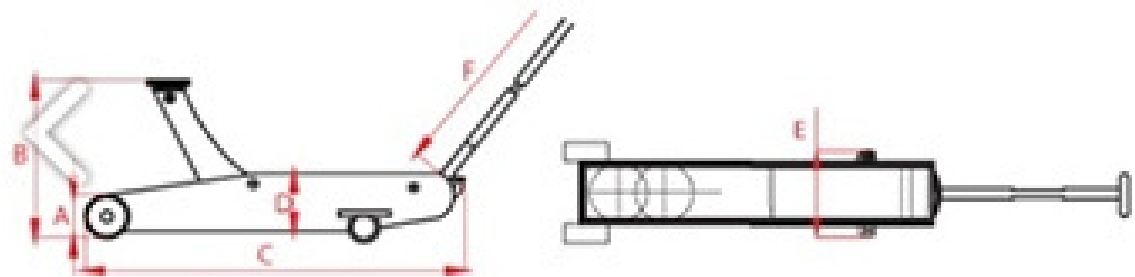



## HPK01 2 Stage 40-20 Ton Hydro Pneumatic Jack

### Technical Details

Model	HPK 01
Capacity (Ton)	40 20
Stage	2
Bar	8/12
1. Stage	40
2. Stage	20
A (Mm)	800
B (Mm)	1540
C (Mm)	265
D (Mm)	200
E (Mm)	370
Weight (Kg)	75

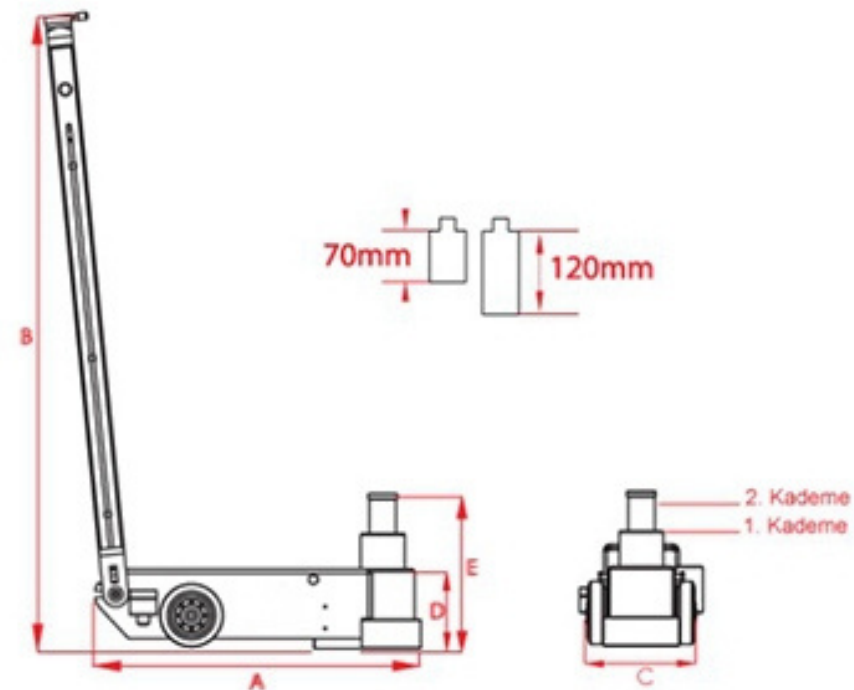





**HPK02**  
3 Stage 70-40-20 Ton Hydro Pneumatic Jack

**Technical Details**



Model	HPK 02
Capacity (Ton)	70 40 20
Stage	3
Bar	8/12
1. Stage	70
2. Stage	40
3. Stage	20
A (Mm)	900
B (Mm)	1300
C (Mm)	320
D (Mm)	185
E (Mm)	420
Weight (Kg)	92

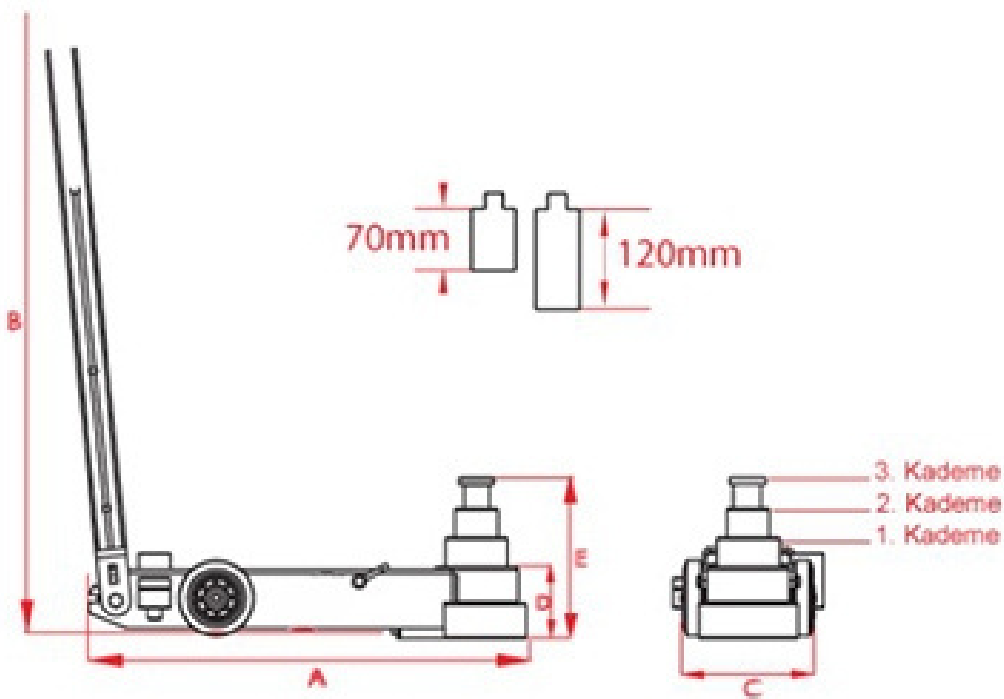



## HPK03 2 Stage Mobile 30-15 Tons Hydropneumatic Jack

### Technical Details



Model	HPK 03
Capacity (Ton)	30 15
Stage	2
Bar	8/12
1. Stage	30
2. Stage	15
A (Mm)	640
B (Mm)	1440
C (Mm)	280
D (Mm)	170
E (Mm)	330
Weight (Kg)	50

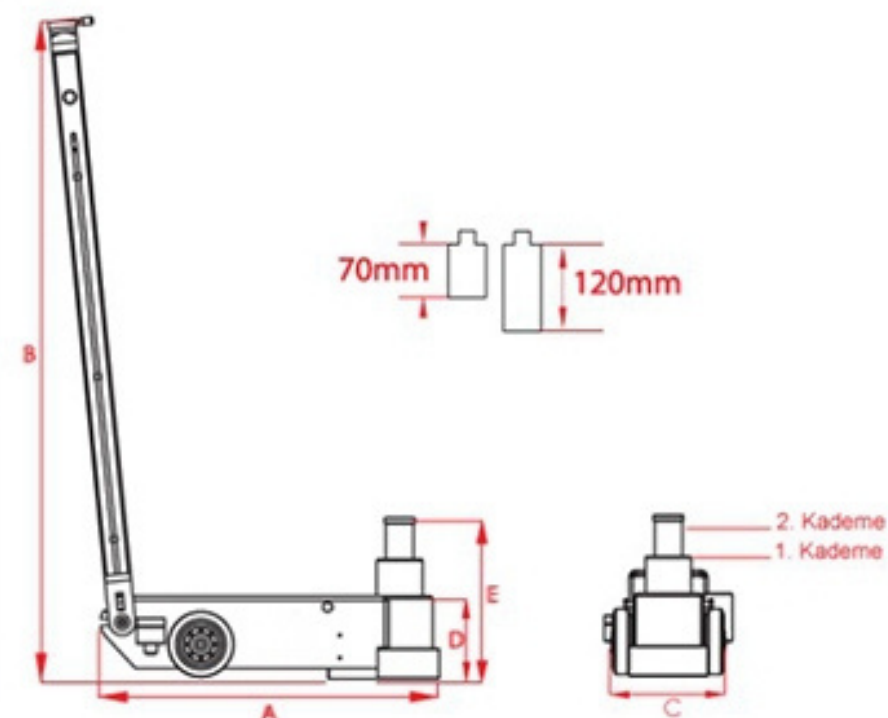



**HPK04**  
**3 Stage 45-15 Ton Hydro Pneumatic Jack**

**Technical Details**



Model	HPK 04
Capacity (Ton)	45 30 15
Stage	3
Bar	8/12
1. Stage	45
2. Stage	30
3. Stage	15
A (Mm)	900
B (Mm)	1300
C (Mm)	270
D (Mm)	150
E (Mm)	320
Weight (Kg)	84

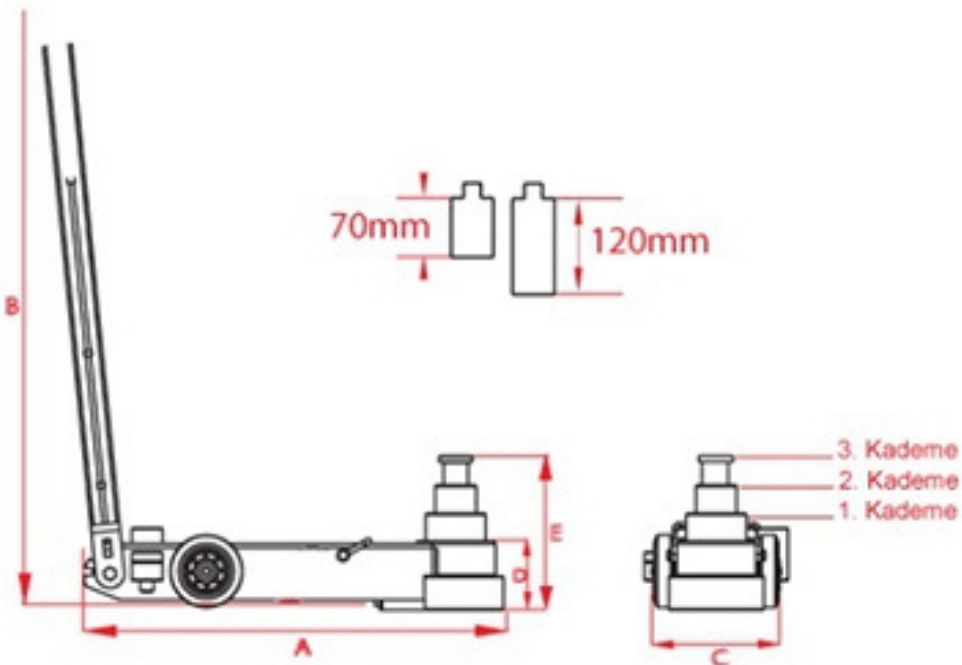



## BJ03 3 Ton Bellows Jack

### Technical Details



Model	BJ 03
Capacity (Ton)	2
Jack Type	Pneumatic
Max Height (mm)	350
Min Height (mm)	160
Operating Pressure (Bar)	8
Weight (Kg)	35



## MS500 Engine Removal Stand

### Technical Details



Capacity (Kg)	500
Model	MS 500
Weight (Kg)	32





## MA500 Engine Suspension



### Technical Details

Capacity (Kg)	500
Model	MA 500
Weight (Kg)	18



## SKD500 Vertical Transmission Jack

### Technical Details

Model	SKD 500
Capacity (Kg)	500
B (Mm)	540
C (Mm)	1200
D (Mm)	2000
E (Mm)	315
Weight (Kg)	30





## SKY01 Horizontal Transmission Jack 1 Ton

### Technical Details



Model	SKY 01
Capacity (Ton)	1
A (Mm)	1000
B (Mm)	520
C (Mm)	290
D (Mm)	780
E (Mm)	640
F (Mm)	370
Weight (Kg)	55





SKY02  
Horizontal Transmission Jack 2 Ton

Technical Details



Model	SKY 02
Capacity (Ton)	2
A (Mm)	1020
B (Mm)	510
C (Mm)	230
D (Mm)	850
E (Mm)	640
F (Mm)	370
Weight (Kg)	77



## KL15 Scissor Lift Download Jack



### Technical Details

Model	KL 15
Capacity (Ton)	15
Strok Lenght (Mm)	50





## GET IN TOUCH

**HEAD OFFICE**  
Fatih Mh. Oto Parçacılar Sitesi Boyluca Sk. C  
Blok No:28 Selçuklu/Konya/TURKEY  
+90 332 352 62 11  
info@garagetechnic.com

**BRANCH OFFICE**  
Hacımimi Mah. Lüleci Hendek Cad. No:47A  
Beyoğlu / İstanbul / TURKEY  
+90 212 356 96 16  
info@garagetechnic.com

[www.garagetechnic.com](http://www.garagetechnic.com)